

# Applied

## Grade 9 Assessment of Mathematics

Spring 2008

### **SAMPLE ASSESSMENT QUESTIONS**

**Record your answers to the multiple-choice questions  
on the blank Student Answer Sheet (Spring 2008, Applied).**

Education Quality and  
Accountability Office



Please note: The format of these booklets is slightly different from that used for the assessment. The items themselves remain the same.

- 1** A carton that holds 500 mL of chocolate milk costs \$2.29.

Which of the following containers has a lower cost per mL?

- a 250 mL at \$1.29
- b 700 mL at \$3.09
- c 750 mL at \$3.59
- d 1000 mL at \$4.69

- 2** Which of the following fractions is **not** equivalent to  $\frac{10}{30}$ ?

- a  $\frac{2}{6}$
- b  $\frac{15}{35}$
- c  $\frac{1}{3}$
- d  $\frac{100}{300}$

- 3** Aidan is buying a new CD player. The CD player was selling for \$84.79 and now is on sale for 25% off. Which of the following is closest to the total cost of the CD player, including 15% sales tax?

- a \$54.05
- b \$63.59
- c \$73.13
- d \$74.49

- 4** What is the value of the expression

$$-1 + \frac{77}{100}?$$

- a  $-\frac{177}{100}$
- b  $-\frac{78}{100}$
- c  $-\frac{76}{100}$
- d  $-\frac{23}{100}$

- 5** A rocket is fired upward from the ground. The equation below shows the relationship between  $h$ , the height of the rocket above the ground in metres, and  $t$ , the time in seconds.

$$h = 60t - 5t^2$$

Which of the following is the height of the rocket after 4 seconds?

- a 35 m
- b 44 m
- c 160 m
- d 240 m

**6 Clarence's Quandary**

Clarence works at a veterinarian's office. He needs to give a dose of medicine to a 24 kg dog. The recommended dosage for a dog that weighs 10 kg is 25 mL. Determine the dose Clarence should give to the 24 kg dog if the rate remains the same. Show your work.



- 7** Mia delivers the local newspaper. Her base pay is \$5 per week, and she gets \$0.25 per paper.

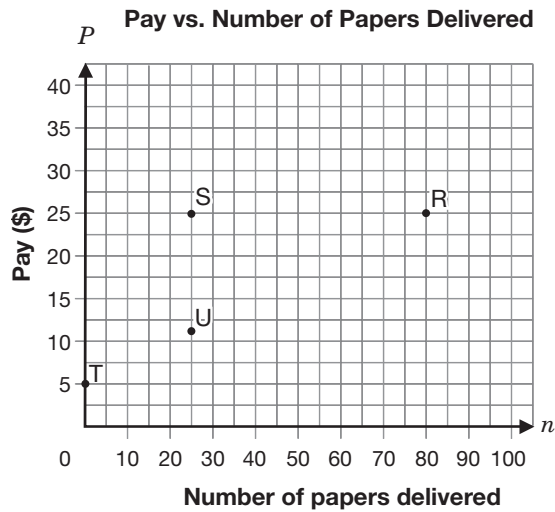

Which of the points on the graph represents Mia’s pay for delivering 25 newspapers in a week?

- a Point R
- b Point S
- c Point T
- d Point U

- 8** Yves records the time of day that a street light turns off for 9 mornings over 28 days. The graph shows his data from the first day of the month.

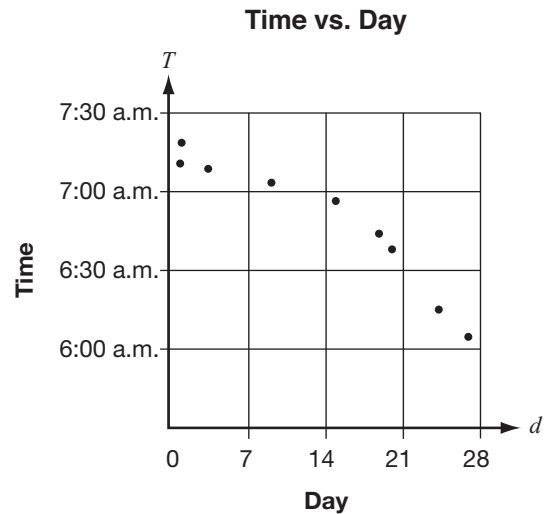

Which statement describes the relation above?

- a The later in the month, the later the street light turns off.
- b The later in the month, the earlier the street light turns off.
- c The earlier in the month, the earlier the street light turns off.
- d There is no relationship between the day and the time the street light turns off.

- 9** Victoria is selling chocolate bars to raise money for her hockey team. She begins with 36 bars to sell and sells four bars per day.

Which of the following represents the relation between  $N$ , the number of chocolate bars remaining, and  $d$ , the number of days she has been selling?

- a  $N = 36 + 4d$   
 b  $N = 36d - 4$

c

Day, $d$	Number of bars remaining, $N$	First differences
0	20	
1	24	4
2	28	4
3	32	4
4	36	4

d

Day, $d$	Number of bars remaining, $N$	First differences
0	36	
1	32	-4
2	28	-4
3	24	-4
4	20	-4

- 10** Tyler belongs to a fitness club at the community centre. The graph below represents the relationship between the number of times he visits the club and his total monthly cost.

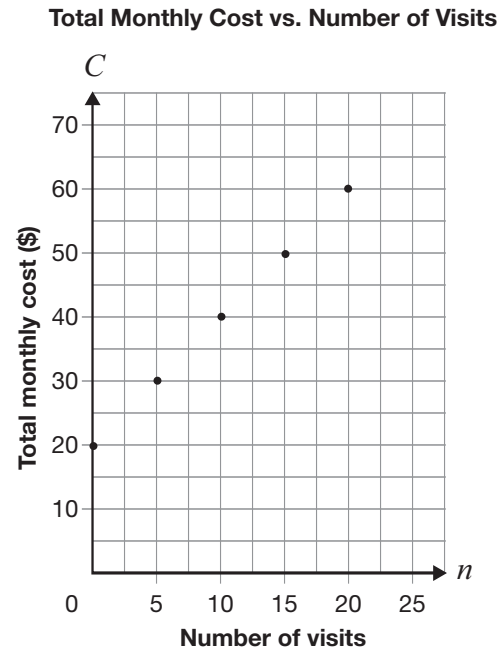

What type of variation is this relationship, and what is the initial value?

- a Direct variation, and initial value is 0  
 b Partial variation, and initial value is 0  
 c Direct variation, and initial value is 20  
 d Partial variation, and initial value is 20

**11** Karl joins a fitness centre. The cost includes a one-time fee of \$100 plus a monthly fee of \$30. If  $C$  represents his total cost and  $n$  is the number of months, which equation represents this relationship?

- a  $C = 130n$
- b  $C = 100n + 30$
- c  $C = 30n + 100$
- d  $C = n + 130$

**12** The relationship between  $t$ , the number of minutes Shufrah travels, and  $D$ , the distance she is from home, is shown on the grid below.

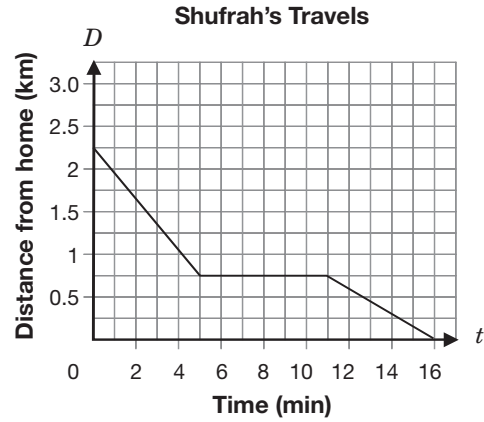

Which of the following statements best describes the way Shufrah travels?

- a While travelling toward her home, Shufrah rides her bike, stops and then walks.
- b While travelling toward her home, Shufrah rides her bike, walks and then rides her bike.
- c While travelling away from home, Shufrah rides her bike, stops and then walks.
- d While travelling away from home, Shufrah walks, rides her bike and then walks.

- 13** A jewellery store sells bead necklaces. Each necklace costs \$4 for the wire and \$0.25 per bead.

Select the answer below that represents this relation **correctly** in two ways.  $C$  is the cost in dollars and  $n$  is the number of beads.

**a** Cost vs. Number of Beads

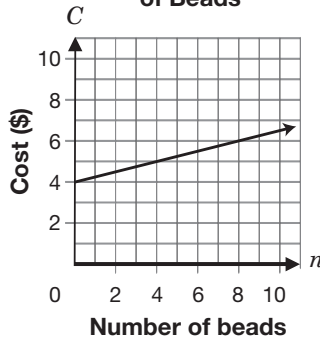

Number of beads, $n$	Cost, $C$ \$
0	0
5	1.25
10	2.50
15	3.75
20	5.00

**b**  $C = 4n + 0.25$

Number of beads, $n$	Cost, $C$ \$
0	4.00
5	5.25
10	6.50
15	7.75
20	9.00

**c**  $C = 0.25n + 4$

Cost vs. Number of Beads

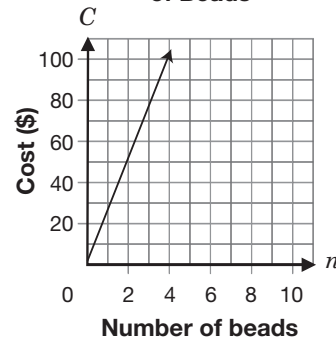

**d** Cost vs. Number of Beads

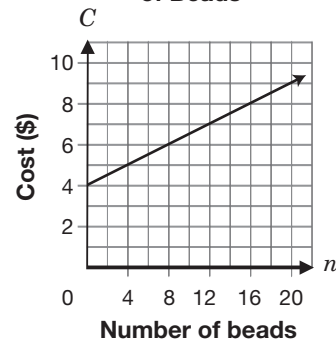

Number of beads, $n$	Cost, $C$ \$
0	4.00
5	5.25
10	6.50
15	7.75
20	9.00

- 14** U-Rent-Skates charges an \$8 fee, plus \$3.50 per hour to rent skates.

How long can Zara skate if she has a total of \$22 and still needs to keep \$1.50 for bus fare?

- a** 3 hours  
**b** 4 hours  
**c** 5 hours  
**d** 6 hours

**15 Starting Costs**

A car rental company uses the equation  $C = 20 + 0.15d$  to determine the cost of renting a car, where  $C$  is the total cost in dollars and  $d$  is the distance travelled in kilometres.

Determine the initial value and the rate of change.

Initial value \_\_\_\_\_

Rate of change \_\_\_\_\_

Describe how the initial value and the rate of change relate to the total cost of renting a car.





**16 Let's Go to a Water Park!**

Two water parks have different methods of determining the cost of a season pass. The equations for both parks are given below, where  $C$  is the cost of the pass and  $n$  is the number of visits.

**Wet Water World**

$C = 20 + 10n$	
Number of visits, $n$	Total cost, $C$ (\$)
0	
2	
4	
6	
8	

**Bubbling Blue**

$C = 50 + 5n$	
Number of visits, $n$	Total cost, $C$ (\$)
0	
2	
4	
6	
8	

Graph the costs for both water parks on the grid below.

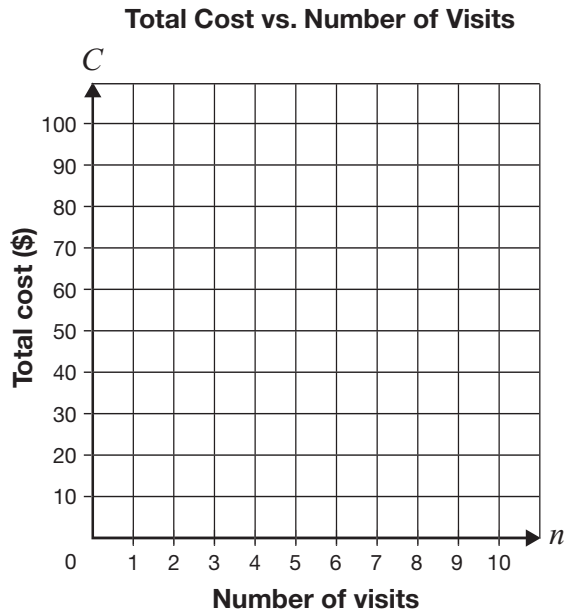

Determine which water park has the lower cost for a season pass.

Justify your answer.

- 17** Germaine wants to calculate the area of the shape shown below. It is composed of a rectangle and two semicircles.



Which of the following pairs of expressions should Germaine use to determine the area of the shape?

- a  $2(l + w), \pi r^2$
  - b  $2(l + w), 2\pi r$
  - c  $lw, 2\pi r$
  - d  $lw, \pi r^2$
- 18** Silvia is making lemonade. She is using a cylindrical container with a radius of 10 cm and a height of 30 cm, as shown below.

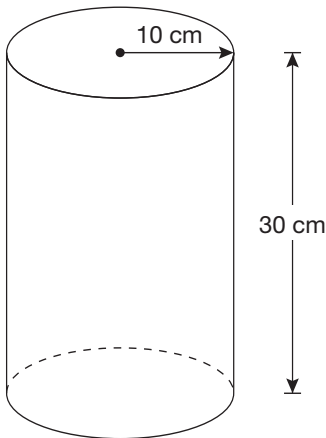

Which of the following is closest to the volume of the container?

- a  $37\,700\text{ cm}^3$
- b  $9425\text{ cm}^3$
- c  $1885\text{ cm}^3$
- d  $600\text{ cm}^3$

- 19** A custodian uses a lift to change light bulbs in the gym. A cross-section of the lift is shown below.

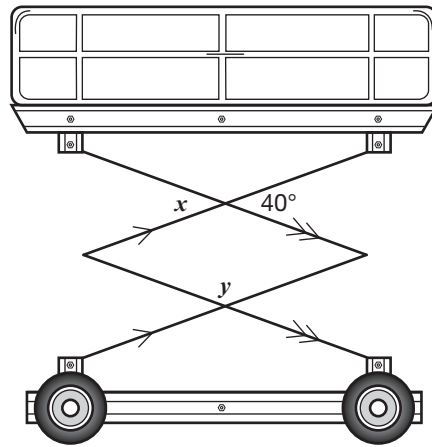

What are the values of  $x$  and  $y$ ?

- a  $x = 40^\circ, y = 100^\circ$
  - b  $x = 40^\circ, y = 140^\circ$
  - c  $x = 50^\circ, y = 130^\circ$
  - d  $x = 50^\circ, y = 140^\circ$
- 20** The measure of  $\angle ACB$  is  $39^\circ$ .

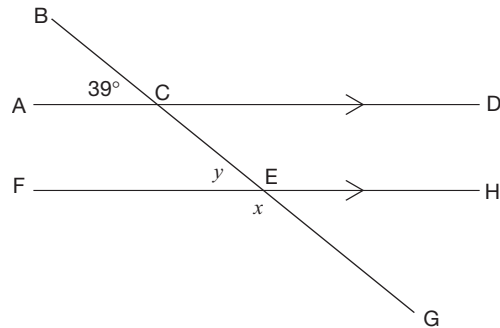

What are the values of  $x$  and  $y$ ?

- a  $x = 39^\circ$  and  $y = 141^\circ$
- b  $x = 39^\circ$  and  $y = 39^\circ$
- c  $x = 141^\circ$  and  $y = 141^\circ$
- d  $x = 141^\circ$  and  $y = 39^\circ$

**21 Determining Degrees**

Consider the following diagram.

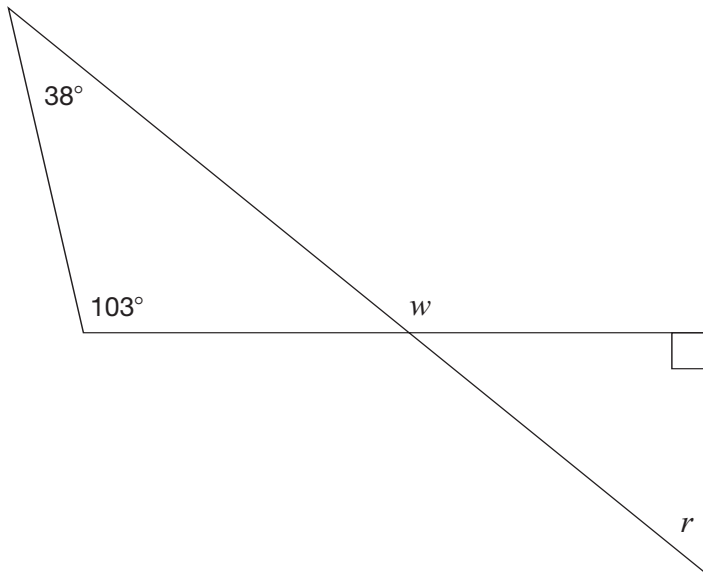

Determine the values of  $r$  and  $w$ .

Justify your answer.

	Value	Justification
$r$		
$w$		

## Sample Assessment Questions: Applied

### Answer Key

1.  a  b  c  d
2.  a  b  c  d
3.  a  b  c  d
4.  a  b  c  d
5.  a  b  c  d
6. Respond in booklet.

7.  a  b  c  d
8.  a  b  c  d
9.  a  b  c  d
10.  a  b  c  d
11.  a  b  c  d

12.  a  b  c  d
13.  a  b  c  d
14.  a  b  c  d
15. Respond in booklet.
16. Respond in booklet.

17.  a  b  c  d
18.  a  b  c  d
19.  a  b  c  d
20.  a  b  c  d
21. Respond in booklet.

**End of Assessment**