



Applied

Grade 9 Assessment of Mathematics

Spring 2006



Education
Quality and
Accountability
Office

Please note: The format of these booklets is slightly different from that used for the assessment. The items themselves remain the same.

1. Study the distance chart below.

	Banff	Calgary	Columbia Icefield	Edmonton
Calgary	128			
Columbia Icefield	188	316		
Edmonton	423	295	461	
Lake Louise	58	186	130	481

Distances are shown in kilometres.

Tim drives from Edmonton to the Columbia Icefield at an average speed of 60 km/h.



About how long does his trip take?

- a 5 h
- b 6 h
- c 7 h
- d 8 h *

2. Emily burns **2500 kJ/h** when she runs. To regain the energy she spends, Emily eats apples. An apple gives her **420 kJ** of energy.



How many apples must Emily eat to regain all of her energy when she runs for **1 h**?

- a approximately 6 apples *
- b approximately 4.5 apples
- c approximately 3.5 apples
- d approximately 2 apples

3. Examine the diagram below.

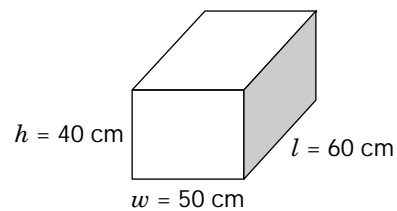

Which statement is **true**?

- a The height is 40% of the width.
- b The height is 50% of the length.
- c The height is 80% of the width.*
- d The height is 125% of the width.

4. Calculate $7^2 + 6 - 8 \div 2 + 2$.
- a 18
 - b 49
 - c 50
 - d 53 *
5. Stephen's earnings are calculated according to the formula

$$\text{Earnings} = 7t + \frac{d}{20}$$

where t is the number of hours Stephen works and d is the dollar value of the clothes he sells in the week.

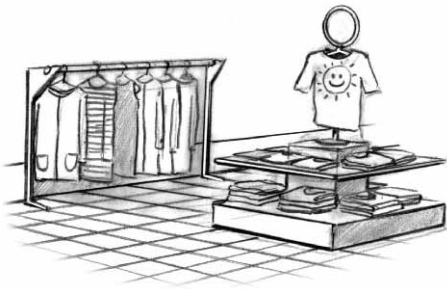

One week, Stephen works for 15 h and sells \$980 worth of clothes. How much does he earn?

- a \$54.25
- b \$105
- c \$154 *
- d \$176

6. Study the graph below, which shows how the percent of the Canadian population that is non-farm rural has varied over time.

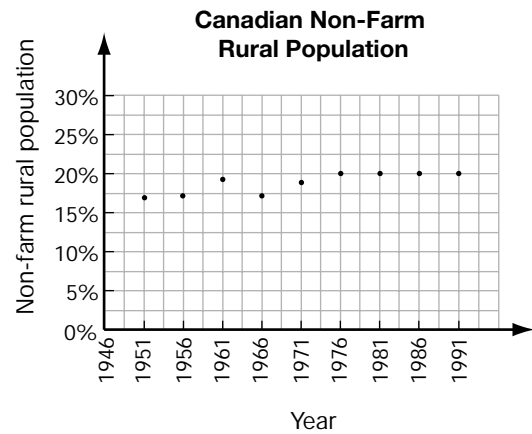

Which statement about the percent is true?

- a It stayed constant from 1951 to 1991.
- b It increased from 1966 to 1976. *
- c It decreased at a constant rate from 1961 to 1981.
- d It increased at a constant rate from 1951 to 1971.

7. Karen collects data on the heights, in centimetres, and the ages, in years, of seven students in the school cafeteria. She enters the data into lists, using a graphing calculator.

L1	L2	L3	Z
13	148	-----	
14	165		
15	172		
16	175		
16	183		
18	195		
18	179		
L2(1)=148			

Which of the following scatter plots best matches the data points?

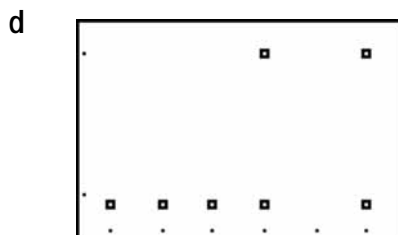
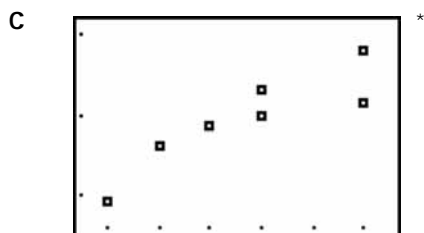
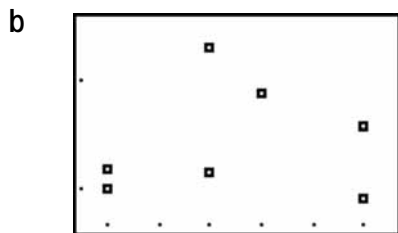
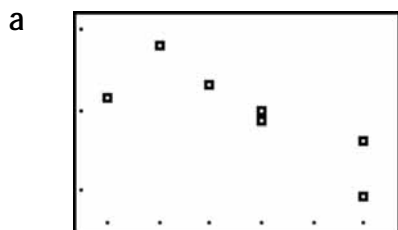

8. On a warm March day, Julie notices that the height of a snow bank is **decreasing** at an average rate of 2 cm/h.

Which graph illustrates the relationship between the height of the snow bank, in centimetres, and time, in hours?

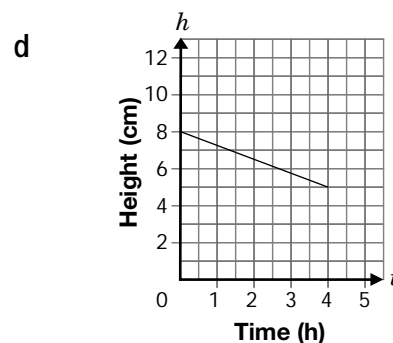
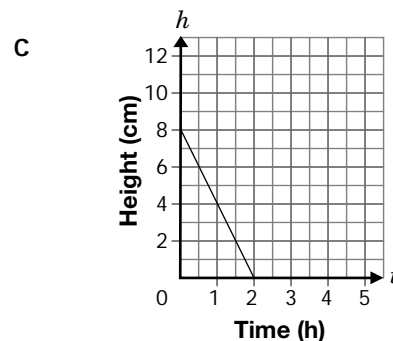
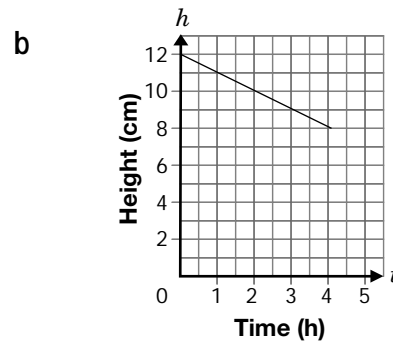
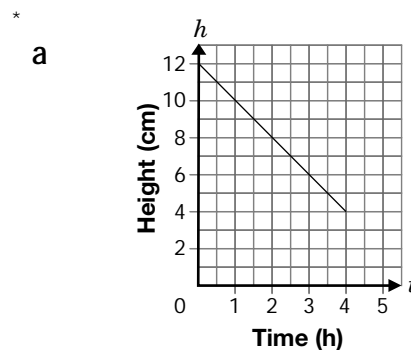

9. Jean buys a membership at a golf course. She pays an initial fee of \$200, **plus** \$22.50 every time she plays.



Which equation represents the relationship between the total cost, C , and the number of games played, n ?

- a $C = -22.5n + 200$
- b $C = 22.5n + 200$ *
- c $C = 200n + 22.5$
- d $C = 200n - 22.5$

10. The graph below represents the relationship between the height, h , in metres, and the age, a , in years, of a tree.

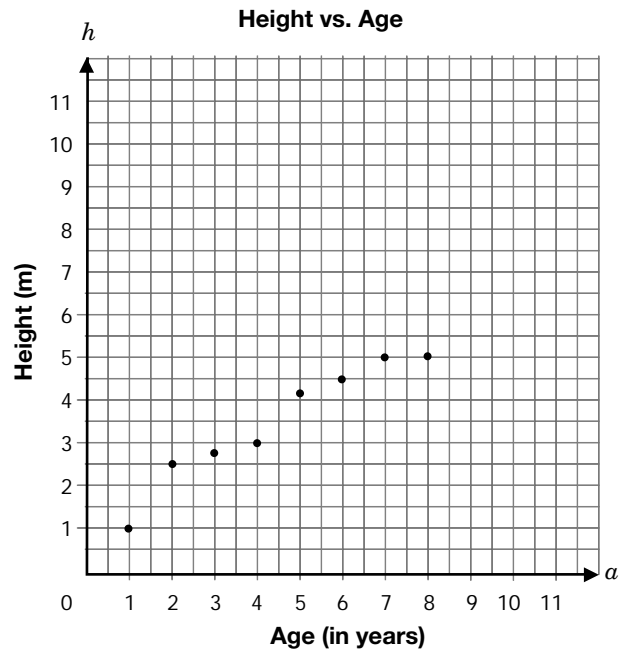

What is the approximate **height** of the tree if it is **10 years old**?

- a 10.5 m
- b 8.5 m
- c 6.5 m *
- d 4.5

11. Daniel works full-time at a restaurant. The graph shows the relationship between Daniel's earnings for a week and the number of hours worked.

Earnings vs. Number of Hours Worked

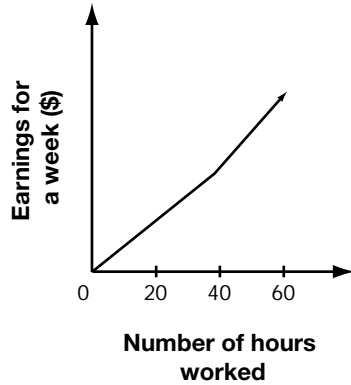

Which statement best describes how Daniel's work conditions change when he works more than 40 h in the week?

- a He is paid a one-time bonus.
- b He works at a faster rate.
- c He is paid at a higher rate. *
- d He gets promoted to a higher rank.

12. A rectangle has a perimeter of 60 cm.

Which dimensions will ensure the rectangle has the largest possible area?

- a 29 cm by 1 cm
- b 25 cm by 5 cm
- c 20 cm by 10 cm
- d 15 cm by 15 cm *

13. Examine the figure below.

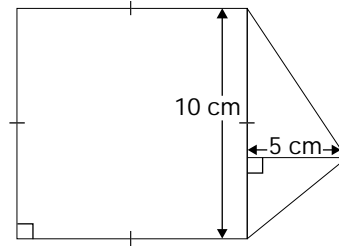

What is the **total area** of the figure?

- a 150 cm^2
- b 145 cm^2
- c 140 cm^2
- d 125 cm^2 *

14. A piece of bristol board has dimensions $20\text{ cm} \times 15\text{ cm}$. David cuts a circular hole with a diameter of 8 cm in the board.

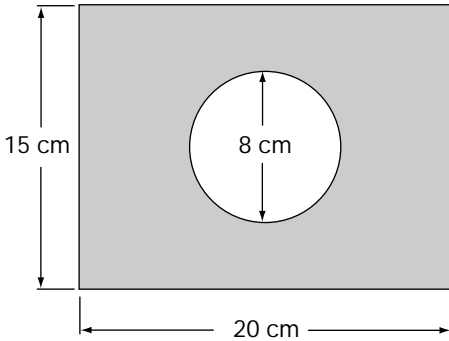

Which expression could be used to calculate the area of the bristol board after the hole has been cut?

- a $(15)(20) - 4\pi$
- b $(15)(20) - 8^2$
- c $(15)(20) - \pi(4)^2$ *
- d $(15 - 8)(20 - 8)$

15. In science class, Derek uses a funnel, in the shape of a cone, to pour water into a beaker.

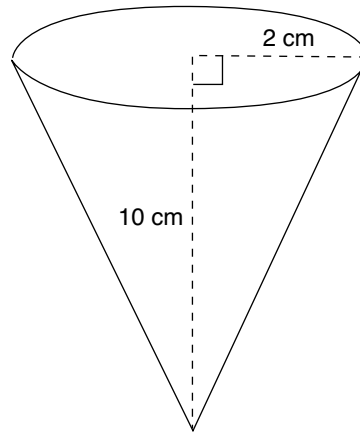

The volume of the funnel, to the nearest whole number, is

- a 42 cm^3 *
- b 126 cm^3
- c 168 cm^3
- d 378 cm^3

16. In the figure, AB is parallel to CD .

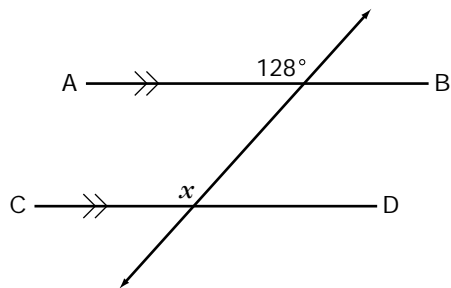

What is the value of x ?

- a 38°
- b 52°
- c 62°
- d 128° *

1. Computer Repair

Gurshaarn takes his broken computer to **Rapid Repair**.

At **Rapid Repair**, the total repair cost includes a fixed cost of \$25 plus \$20/h for labour.



- a) Complete the table below to show the relationship between total repair cost, C , in dollars, and time, t , in hours.

Time, t (h)	Total repair cost, C (\$)
0.5	
1	$25 + 20(1) = 45$
1.5	
2	
2.5	$25 + 20(2.5) = 75$
3	

- b) Construct a graph of the relationship between total repair cost, C , in dollars, and time, t , in hours.

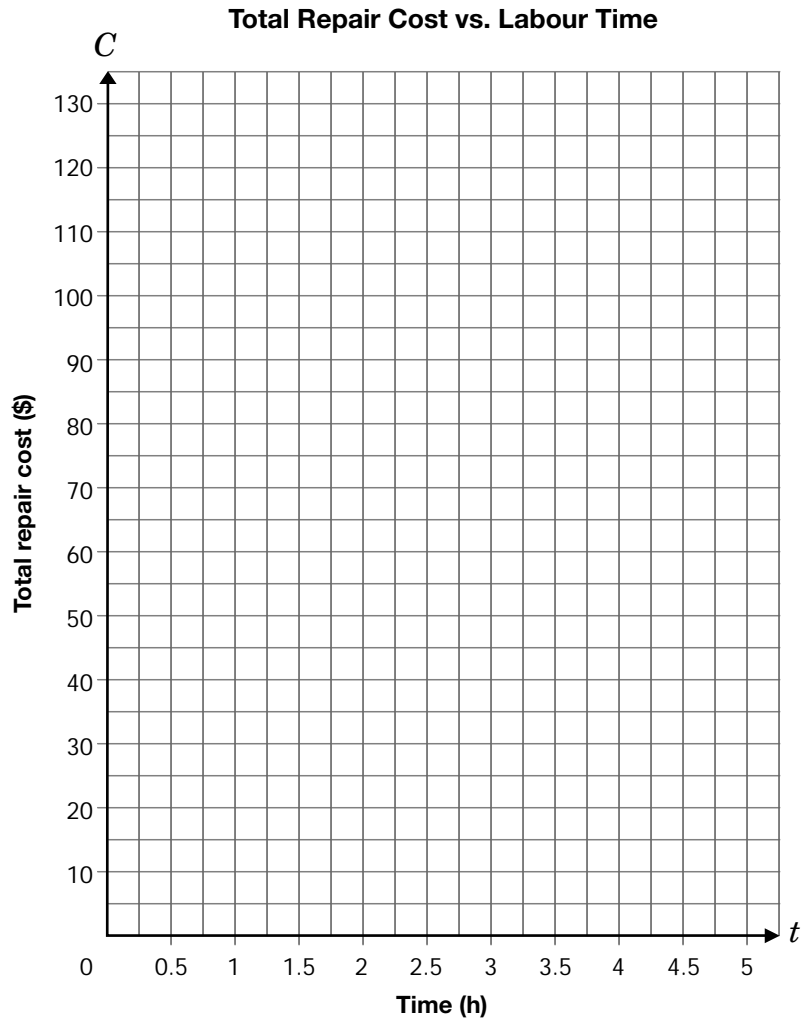

- c) Determine the **time** if the total cost of the repair is **\$125.00**.
Justify your answer.

- d) A different company charges a **flat rate** for up to **2 h** of repair on any computer.
After this, an hourly rate is applied.

Circle the graph (I, II or III) that represents this relationship.

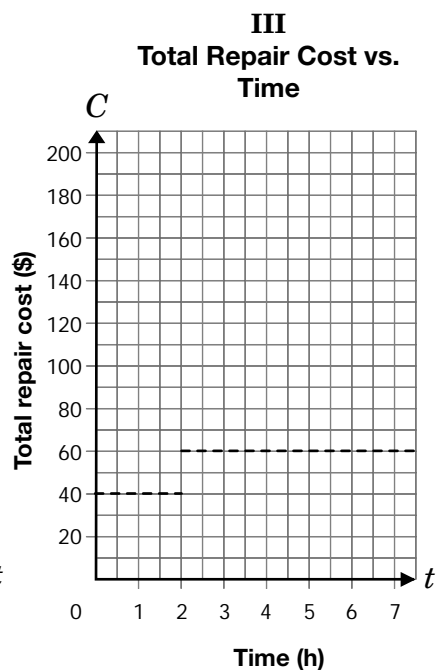
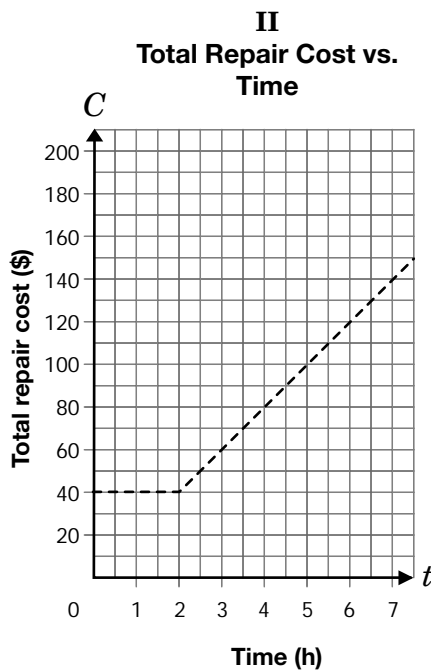
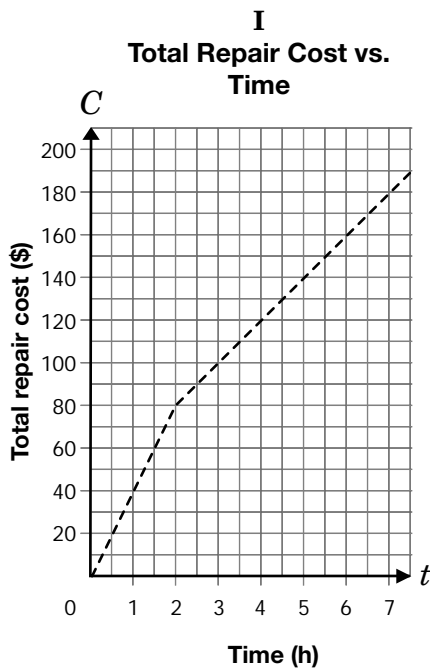

Justify your choice of graph.

2. The Wind in the Sail

Marco is designing a new sail for his windsurfer.

He uses the quadrilateral below as the design of one part of the sail.

- a) Determine the value of x in the quadrilateral by solving the equation.

$$78 + x + 2x + 90 = 360$$

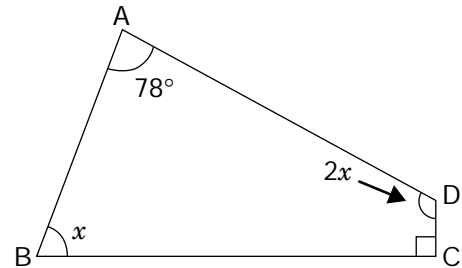
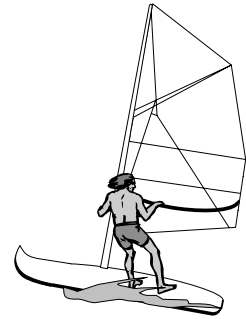

The bottom part of the sail is made of two rectangles.

A bar labelled ED crosses the two rectangles.

- b) Determine the measures of $\angle w$ and $\angle y$ in the diagram below. Justify your answers.

Angle	Angle measure	Reason
$\angle w$		
$\angle y$		

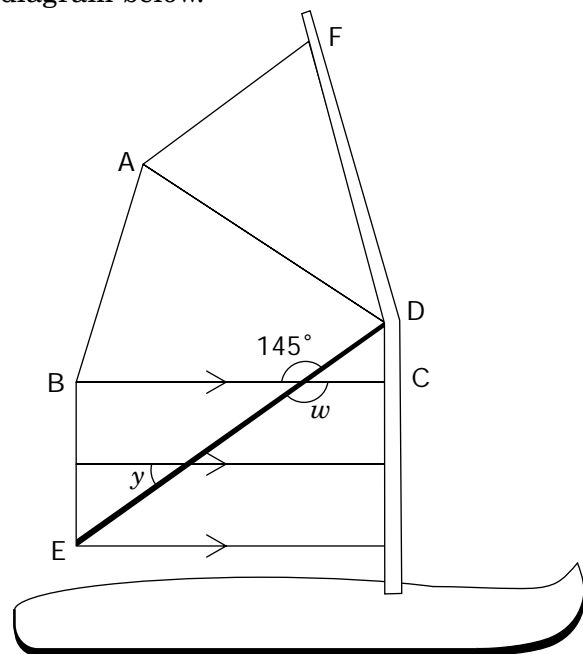

Marco needs to know the area of the quadrilateral part of the sail. He adds line BD to create 2 triangles and takes the measurements shown in the diagram.

- c) Determine the total area of the quadrilateral by calculating and adding the areas of the triangles.
Show your work.

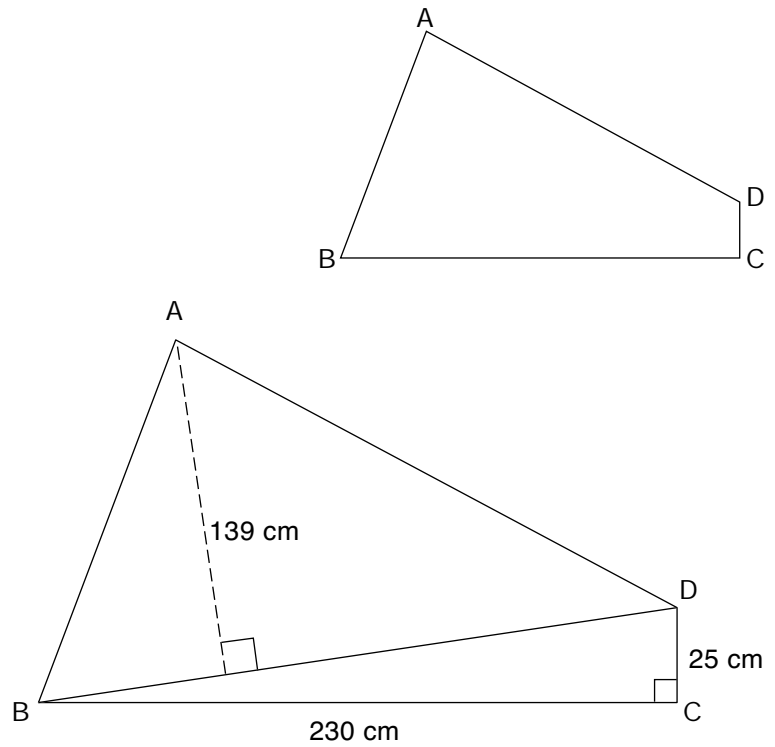

Marco is making the sail using green and red material in the ratio 3:2. He needs a total of 4.5 m^2 of material.

- d) Determine how much **red** material he needs.
Show your work.

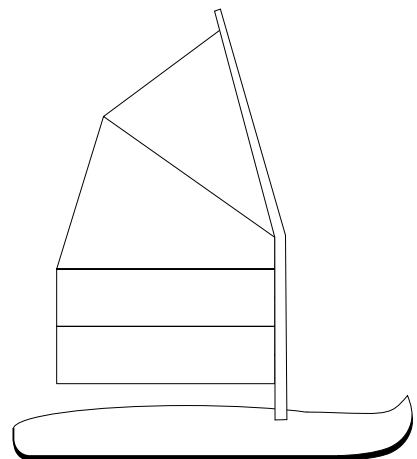

The information in this booklet is being collected under authority of clause 4 (1) (b) and subsection 9 (6) of the *Education Quality and Accountability Office Act, 1996*, for the purposes of administering and marking tests of pupils in secondary schools and evaluating the quality and effectiveness of secondary education, in accordance with section 3 of the Act. Inquiries regarding this collection should be directed to the Senior Policy Analyst, EQAO, 2 Carlton Street, Suite 1200, Toronto, ON M5B 2M9 • 1-888-327-7377.

Student responses in this booklet may be used as examples for the marking of the assessment, and may be included without attribution in public reports.

© 2006 Queen's Printer for Ontario.



Education
Quality and
Accountability
Office

All rights reserved. No part of this publication may be reproduced, stored in a retrieval system, or transmitted in any form or by any means, electronic, mechanical, or otherwise, without the prior express written permission of the Education Quality and Accountability Office.